

# RMP60 - radio machine probe

## RMP60 probe system with radio signal transmission.

When switched on, the probe transmits omnidirectionally for ease of operation on vertical, horizontal CNC machining centres and vertical turret lathes.

The RMI is fully described in a separate data sheet - please see parts list on back page.

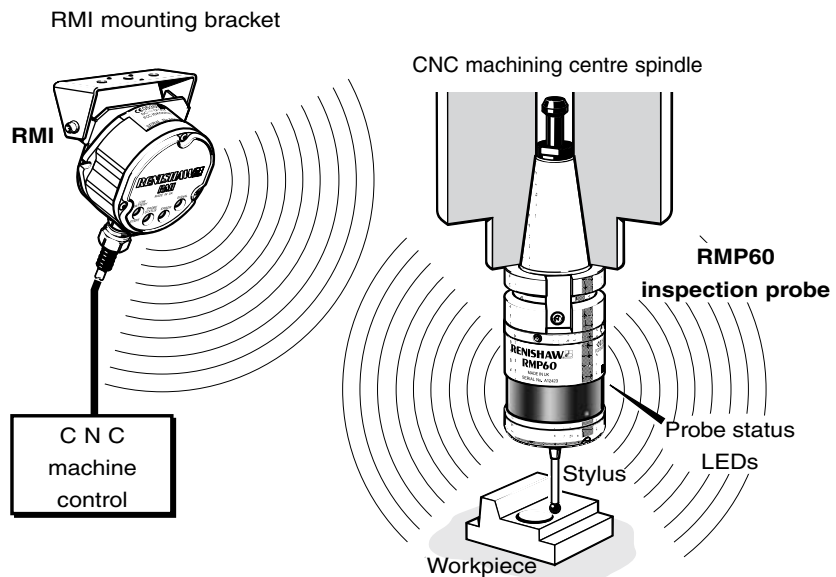

## Features

- The RMP60 is a compact 3D touch-trigger probe ( $\pm X$ ,  $\pm Y$ ,  $+Z$  sense directions) with radio transmission, used for workpiece set-up and inspection on small to large CNC machining centres and vertical turret lathes.
- The RMP60 transmits omnidirectionally with a range of 15 m (49.2 ft).
- Ease of installation.
- A standard battery life of 140 hours continuous use, or the equivalent of approximately 100 days at 5 % usage is achievable. For applications requiring greater battery life, certain high capacity lithium thionyl chloride batteries can be used.
- Repeatability, 1.0  $\mu\text{m}$  (40  $\mu\text{in}$ ) is certified at 480 mm/min (1.57 ft/min) with 50 mm stylus.
- Probe switch on is user configurable between M code, spin or shank.
- Probe switch off is user configurable between M code, time, spin or shank switch dependant on turn on method.
- Sealed to IPX8 for the probe body, IPX5 for the battery cassette, IPX5 with battery cassette removed.
- 2.4 GHz radio transmission, allows single system for worldwide use.
- Interference-free channel hopping transmission.
- No channel selection required.
- RMP60 meets the radio regulations of:
  - Europe: CE 0536!
  - USA: FCC ID: KQGRMP60, FCC ID: KQGRMP60V2, FCC ID: KQGRMP60MV2
  - Japan: RMP60: 004NYCA0042, RMP60: 004NYCA0406, RMP60M: 004NYCA0407
  - Canada: IC: 3928A-RMP60, IC: 3928A-RMP60V2
  - Australia, China, Israel, New Zealand, Russia, Switzerland and India.
- Partner RMP60 and RMI systems allow interference-free multiple probe installations.
- The RMP60 is suitable for use with Renishaw single and double touch probing cycles.
- User adjustable trigger force for long/cranked styli.
- A weak link is included in each kit to protect the probe in the event of excessive stylus overtravel, when using steel styli.

## Operating envelope - RMP60/RMI

The RMP60 transmission envelope and range is shown below.

The probe system should be positioned so that the optimum range can be achieved over the full travel of the machine's axes including the tool magazine. Always face the RMI in the direction of the machine spindle and tool magazine.

If the probe is not in range when in the tool magazine use spin or shank turn on.

The RMP60 and RMI must be within a mutual operating envelope. The operating envelope shows line-of-sight performance. However, radio transmission does not require line-of-sight as long as any reflected radio path is less than the 15 m (49.2 ft) system operating range.

**Range** metres (feet)

■ OPERATING AND SWITCH ON/OFF

### RMP60 probe

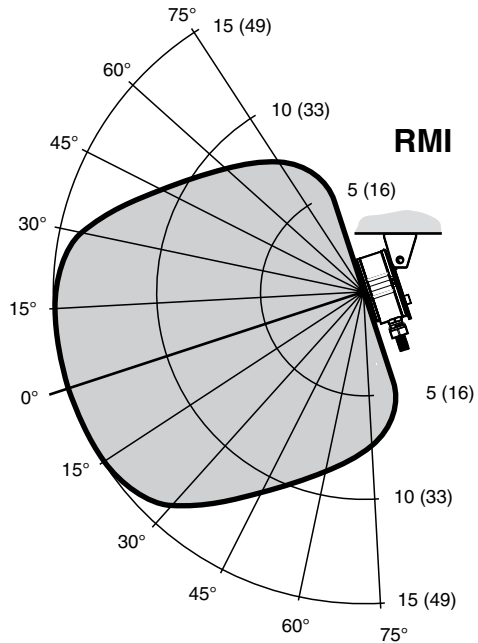
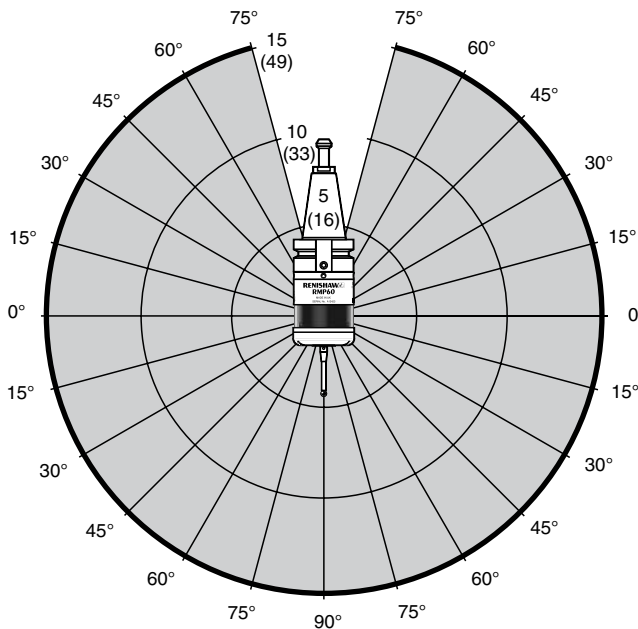

### RMP60 dimensions

dimensions mm (in)

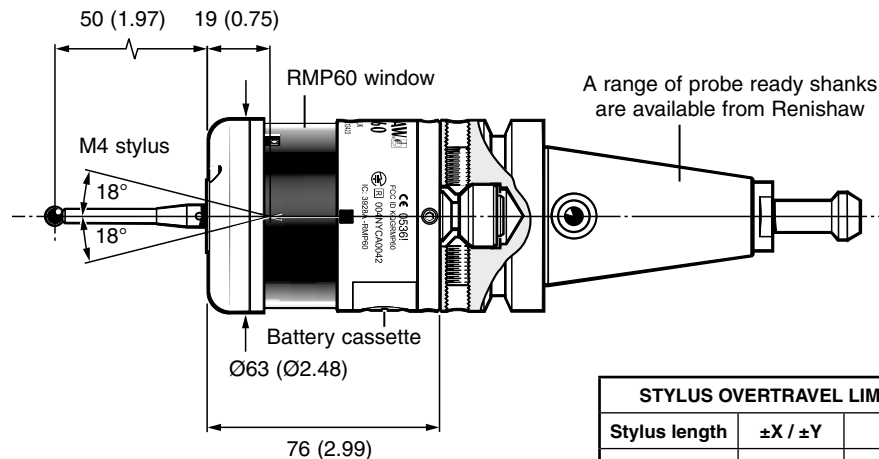

A range of probe ready shanks are available from Renishaw

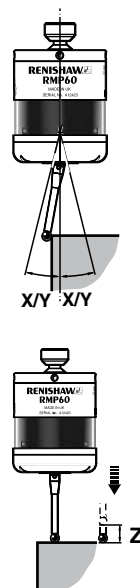

STYLUS OVERTRAVEL LIMITS		
Stylus length	±X / ±Y	Z
50 (1.97)	21 (0.82)	11 (0.43)
100 (3.94)	37 (1.45)	11 (0.43)

## System operation

Prior to probe operation, it is imperative that the program selected to 'drive' the probe has been verified. Incorrect programming could result in damage to the machine, workpiece and probe system.

The RMP60 probe operates in one of three modes:







- Stand-by mode** - The RMP60 uses a small current, while waiting for a switch-on signal to be received.
- Operating mode** - Activated by one of the methods described below. Signals are only transmitted by the probe in this mode and the probe is now ready for use.
- Configuration mode** - Trigger Logic™ allows a number of probe set-up options to be programmed, by triggering the probe when the batteries are inserted. Programmable options are described on the next page.

## Probe environment

RMP60/RMI	Temperature
<b>Storage</b>	-10 °C to 70 °C (14 °F to 158 °F)
<b>Normal operating</b>	5 °C to 50 °C (41 °F to 122 °F)

## Probe status LEDs

When operating the probe status LEDs give a visual indication of the probe state (triggered or seated) and battery condition.

PROBE STATUS LED		
LED Colour	Probe status	Graphic hint
Unit	Stand-by mode or hibernate	
Flashing green	Probe seated in operating mode	
Flashing red	Probe triggered in operating mode	
Flashing green and blue	Probe seated in operating mode - low battery	
Flashing red and blue	Probe triggered in operating mode - low battery	
Constant red	Battery dead	
Rapid flashing red	Extremely dead alkaline batteries or unsuitable lithium thionyl chloride batteries	

**Battery dead** - at this stage probe status is forced open and the probe cycle will stop.

## Probe specification

<b>Primary application</b>	Inspection probe for machining centres
<b>Sense directions</b>	5 way $\pm X \pm Y + Z$
<b>Weight</b> (without a shank) with batteries without batteries	901 g (31.79 oz) 855 g (30.16 oz)
<b>Trigger force</b> using 50 mm (1.97 in) stylus low force direction	<b>factory setting</b> <b>XY</b> 0.75 N / 75 gf (2.65 ozf) <b>Z</b> 5.30 N / 530 gf (18.69 ozf)
<b>Trigger force</b> using 50 mm (1.97 in) stylus high force direction	<b>XY</b> 1.4 N / 140 gf (4.94 ozf) <b>Z</b> 5.30 N / 530 gf (18.69 ozf)
<b>Max. spin speed</b>	1000 rev/min
<b>Overtravel</b>	<b>XY</b> 18° <b>Z</b> 11 mm (0.43 in)
<b>Sealing</b>	IPX8 (BS 5490, IEC 529) 1 atmosphere
<b>Repeatability</b> maximum 2 $\sigma$ value in any direction	1.0 $\mu$ m (0.00004 in) is valid for test velocity of 480 mm/min (1.57 ft/min) at stylus tip, using stylus 50 mm (1.97 in) long.

## Multiple probe mode

RMP60 can be user configured using Trigger Logic™ to allow multiple RMP60s to be used with a single RMI.

### Notes:

Radio turn on cannot be used in multiple probe mode.

RMP60s set to 'mode-on' can coexist alongside any number of RMP60's set to 'mode-off'.

To allow multiple probes/single RMI in close proximity, 16 choices of 'mode-on' colours are available – each representing a different machine tool installation.

Only one of the multiple probes per machine will need partnering as, by configuring multiple probes to a single 'mode-on' choice, all probes have the same identification. The probe to be partnered is partnered after selection of multiple probe on mode.

There is no limit to the number of probes that can be used with a single RMI as long as they all have the same 'mode-on' colour choice.

All RMP60s are factory-set to 'mode off'.

The addition of further probe(s) into a single probe installation requires all probes to be re-configured to the same multiple probe 'mode-on' choice and the repartnering of one of the probes to the installed RMI.

The addition of further probes (or replacements) into a multi probe installation is achieved simply by reconfiguration to the same 'mode-on' colour choice.

Comprehensive details of how to set-up and change multiple probe settings are included in the RMP60 installation and user's guide, H-2000-5219.

## Probe switch on and off

The probe is switched on by one of the following options.  
All options are user configurable.

<b>RMP60 switch-on method.</b> Switch-on options are configurable.	<b>RMP60 switch-off method.</b> Switch-off options are configurable.
<b>1. Radio on</b> Radio switch on is commanded by M code. (factory setting).	<b>1. Radio off</b> Radio switch-off is commanded by M code. (factory setting).  A timer automatically switches the probe off after 90 min from the last trigger, if not turned off by M code.
<b>2. Spin start</b> Spin at 650 rev/min for 1 sec minimum (6 sec maximum).	<b>2. Timer off (time out)</b> The RMP60 will time out (12, 33 or 134 sec - user configurable) after the last probe trigger or reset.
<b>3. Shank switch</b>	<b>3. Spin stop</b> Spin at 650 rev/min for 1 sec minimum (6 sec maximum).  A timer automatically switches the probe off after 90 min from last trigger off.
	<b>4. Timer off (time out)</b> The RMP60 will time out (12, 33 or 134 sec - user configurable) after the last probe trigger or reset.
	<b>5. Shank switch off</b>

### Notes:

The RMP60 will be turned on after 1 sec in all modes.

)After being turned on, the RMP60 must be on for a minimum of 1 sec (7 seconds for spin option) before being turned off.

In radio on configuration (either radio on/radio off or radio on/time off) the RMP60 has a built-in hibernate mode. This saves battery life when the RMP60 is in stand-by and the RMI is un-powered (or out of range).

The RMP60 goes into hibernate mode 30 sec after the RMI is un-powered (or out of range). When in this mode, the RMP60 checks for a powered RMI every 30 secs, if the RMI is found, the RMP60 goes from the hibernate mode to stand-by, ready for radio turn on.

## Battery life expectancy

### Typical battery reserve life

Using the standard alkaline battery at 5% usage, typically the probe will continue to operate for approximately 1 week after a low battery warning is first indicated.

Replace the batteries as soon as is practicable.

Rechargeable batteries: either nickel metal hydride (NiMH) or nickel cadmium (NiCd) can be used, but expect a battery life of approximately 50% of the alkaline figures given in the table below.

To achieve stated radio stand-by life, the RMP60 must be in-range of a powered partner RMI.

Battery	Shank/spin turn on		Radio turn on		Continuous use (hours - typical)
	Stand-by life (days - typical)	5% usage 72 minutes/day (days - typical)	Stand-by life (days - typical)	5% usage 72 minutes/day (days - typical)	
<b>Alkaline</b>	650	100	130	65	140
<b>Lithium Thionyl Chloride</b>	1300	200	260	130	280

For applications requiring greater battery life, certain high capacity lithium thionyl chloride batteries can be used.

## RMP60M modular system

RMP60M is a special modular version of RMP60. It enables probe inspection of part features inaccessible to RMP60, by fitting selected adaptors and extensions as shown.

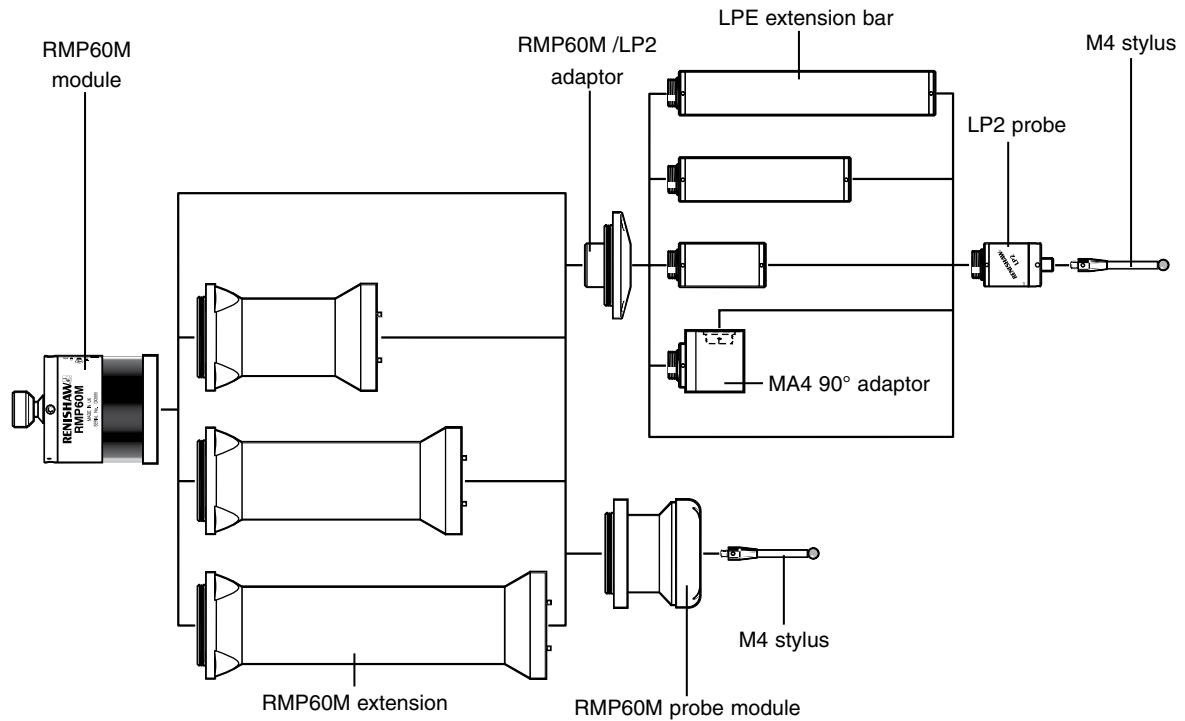

## RMP60M dimensions

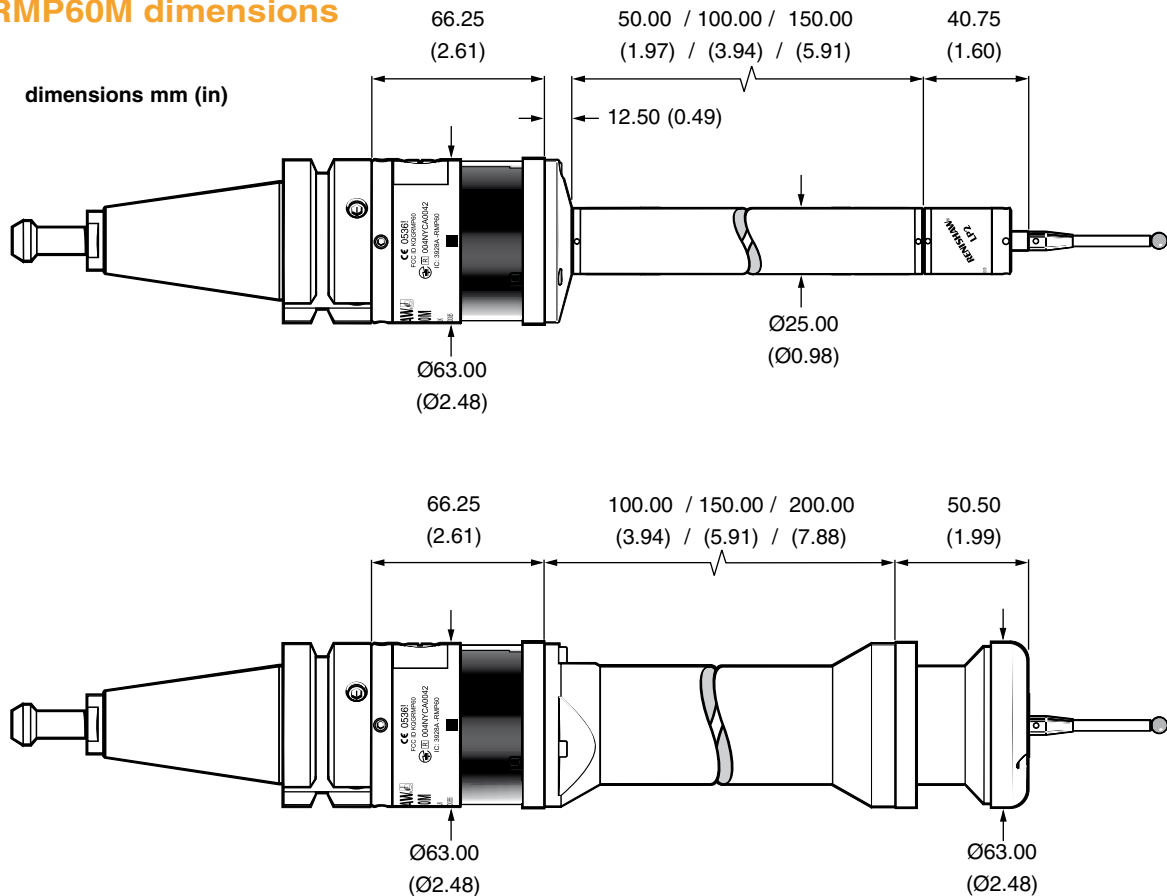

## Parts list - Please quote the Part no. when ordering equipment.

Type	Part no.	Description
RMP60	A-4113-0001	RMP60 probe with batteries, tool kit and user's guide (factory set to radio on/radio off).
RMP60M module	A-4113-1003	RMP60M probe with batteries, tool kit and user's guide (factory set to radio on/radio off).
Battery	P-BT03-0005	AA battery - Alkaline type supplied as standard with probe (two required).
Battery	P-BT03-0008	AA battery - Lithium thionyl chloride (two required).
Stylus	A-5000-3709	PS3-1C ceramic stylus 50 mm long with Ø6 mm ball.
Weak link kit	A-2085-0068	Weak link (Part no. M-2085-0069 x 2) and 5 mm AF spanner.
Tool kit	A-4038-0304	Probe tool kit comprising: Ø1.98 mm stylus tool, 2.0 mm AF hexagon key, 2.5 mm AF hexagon key (x 2), 4 mm AF hexagon key, and shank grub screws (x 2).
Diaphragm kit	A-4038-0302	RMP60 outer diaphragm.
Battery cassette	A-4038-0300	RMP60 battery cassette assembly.
Cassette seal	A-4038-0301	Battery cassette housing seal.
Bobbin kit	A-4038-0303	Bobbin for shank switch (supplied with shank).
RMI	A-4113-0050	RMI, side exit, with 15 m (49.2 ft) cable, tool kit and user's guide.
Mtg brkt	A-2033-0830	Mounting bracket with fixing screws, washers and nuts.
Extension L100	A-4038-1010	RMP60M extension - 100 mm long.
Extension L150	A-4038-1027	RMP60M extension - 150 mm long.
Extension L200	A-4038-1028	RMP60M extension - 200 mm long.
Probe module	A-4038-1002	RMP60M probe module assembly.
RMP60/LP2 adaptor	A-4038-0212	RMP60M LP2 adaptor assembly.
LPE1	A-2063-7001	LPE1 extension bar - 50 mm long.
LPE2	A-2063-7002	LPE2 extension bar - 100 mm long.
LPE3	A-2063-7003	LPE3 extension bar - 150 mm long.
MA4	A-2063-7600	MA4 90° adaptor assembly.
RMP60 user's guide	H-2000-5219	RMP60 user's guide.
Styli	–	See brochure H-1000-3200 Styli and accessories.
Software	–	See data sheet H-2000-2289 Probe software for machine tools.
Shanks	–	See data sheet H-2000-2011 Shanks.
RMI	–	See data sheet H-2000-2123 RMI.

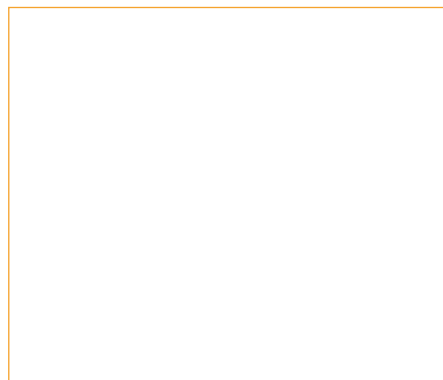

For worldwide contact details, please visit our  
 main web site at [www.renishaw.com/contact](http://www.renishaw.com/contact)



H - 2000 - 2122 - 03